



## POULIČNÉ LED SVIETIDLÁ

SÉRIA LUX -20W

DLP1A1A50A

LM-79

LM-80

DLC

### APLIKÁCIE

Verejné osvetlenie ulíc, parkov, nádvorí.

### MONTÁŽ

Montáž na stĺp verejného osvetlenia vo výške 3m

### TECHNICKÁ ŠPECIFIKÁCIA

Napájanie	AC 100-240V/277V, 50/60Hz
Príkion	20W
Vyžarovací uhol	135x55°
Svetelný tok	95-130LM/W
CRI	70-83 Ra
ČIP	CREE XTE
LED napájač	MEANWELL HLG
Materiál svietidla	Eloxovaný hliník 6063
Optika	PMMC
Svetelný tok	>80000 hod-L70(9K),@25°C
Pracovná teplota	mín 30°C ~ 50°C
Účinník	> 0,9
Krytie	IP66, IK08
Rozmery	431x316x136 mm
Váha	4,2kg

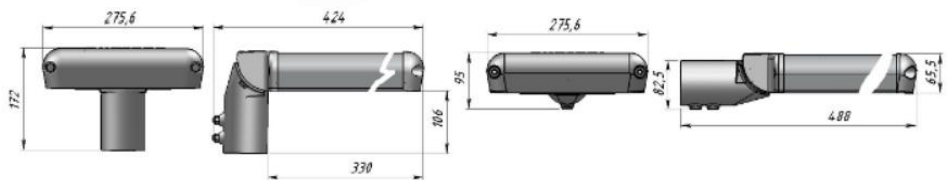
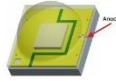

### CERTIFIKÁCIA



### VYŽAROVACIA CHARAKTERISTIKA

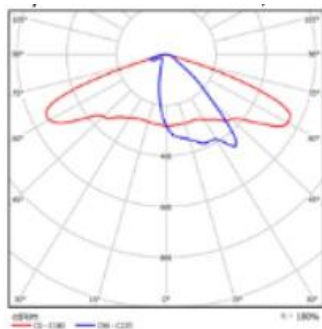

### MONTÁŽ LED SVIETIDLA

Príprava kabeľáže svietidla pre zapojenie

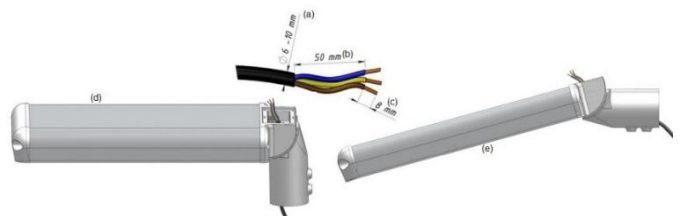

Pripojte vodiče na 3 pólový konektor hnedý -L, modrý -N žltý - uzemnenie, na 2-pólový konektor môžete pripojiť stmievanie drôty. Po pripojení svietidla nastaviť polohu svietidla a zabezpečiť skrutkami.

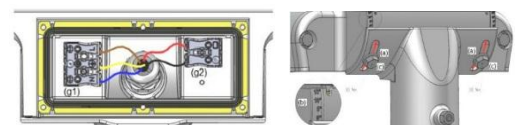
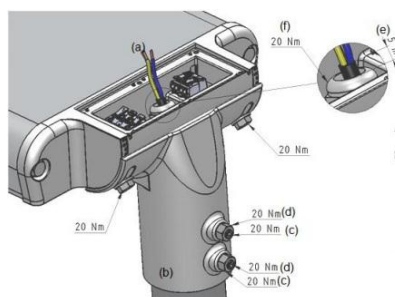



## POULIČNÉ LED SVIETIDLÁ

SÉRIA LUX -38W

DLP1A2A50A

LM-79

LM-80

DLC

### APLIKÁCIE

Verejné osvetlenie ulíc, parkov, nádvorí.

### MONTÁŽ

Montáž na stĺp vrejného osvetlenia vo výške 5-8m

### TECHNICKÁ ŠPECIFIKÁCIA

Napájanie	AC 100-240V/277V, 50/60Hz
Príkonnosť	38W
Vyžarovací uhol	135x55°
Svetelný tok	95-130LM/W
CRI	70-83 Ra
ČIP	CREE XTE
LED napájač	MEANWELL HLG
Materiál svetidla	Eloxovaný hliník 6063
Optika	PMMA
Svetelný tok	>80000 hod-L70(9K), @25°C
Pracovná teplota	mín 30°C ~ 50°C
Účinnosť	> 0,9
Krytie	IP66, IK08
Rozmery	488x275x65,5 mm
Váha	4,6kg

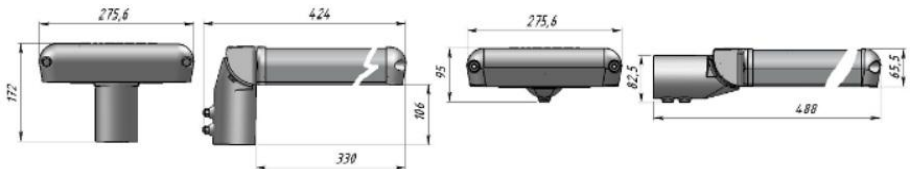
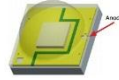

### CERTIFIKÁCIA



### VYŽAROVACIA CHARAKTERISTIKA

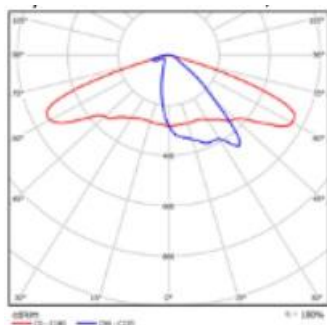

### MONTÁŽ LED SVIETIDLA

Príprava kabeľáže svetidla pre zapojenie

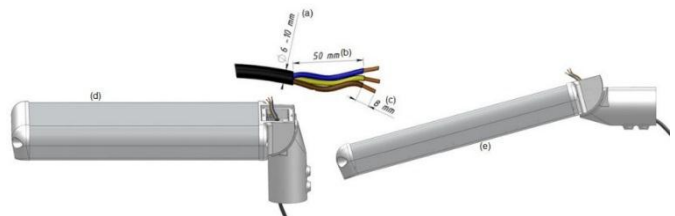

Prípojte vodiče na 3 pólový konektor hnedý -L, modrý -N žltý - uzemnenie, na 2-pólový konektor môžete pripojiť stmievanie drôty. Po pripojení svetidla nastaviť polohu svetidla a zabezpečiť skrutkami.

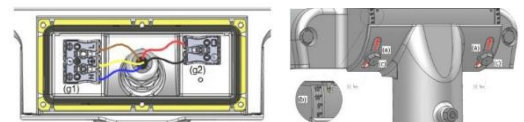
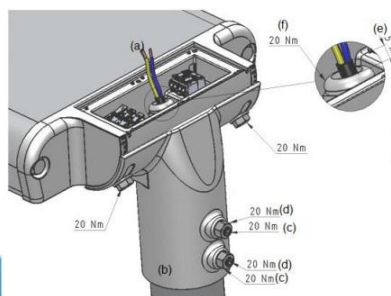



## POULIČNÉ LED SVIETIDLÁ

SÉRIA LUX -54W

DLP1A4B50A

LM-79

LM-80

DLC

### APLIKÁCIE

Verejné osvetlenie ulíc, parkov, nádvorí.

### MONTÁŽ

Montáž na stĺp verejného osvetlenia vo výške 5-8m

### TECHNICKÁ ŠPECIFIKÁCIA

Napájanie	AC 100-240V/277V, 50/60Hz
Príkonnosť	54W
Vyžarovací uhol	135x55°
Svetelný tok	95-130LM/W
CRI	70-83 Ra
ČIP	CREE XTE
LED napájač	MEANWELL HLG
Materiál svetidla	Eloxovaný hliník 6063
Optika	PMMA
Svetelný tok	>80000 hod-L70(9K), @25°C
Pracovná teplota	mín 30°C ~ 50°C
Účinnosť	> 0,9
Krytie	IP66, IK08
Rozmery	658x275x65,5 mm
Váha	6,7kg

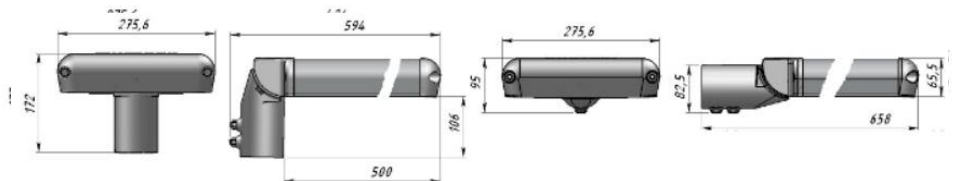

### CERTIFIKÁCIA



### VYŽAROVACIA CHARAKTERISTIKA

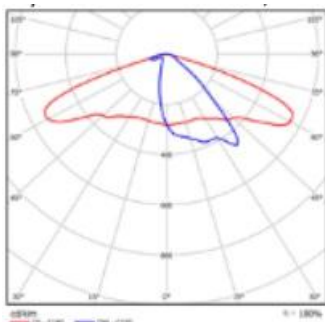

### MONTÁŽ LED SVIETIDLA

Príprava kabeľáže svetidla pre zapojenie

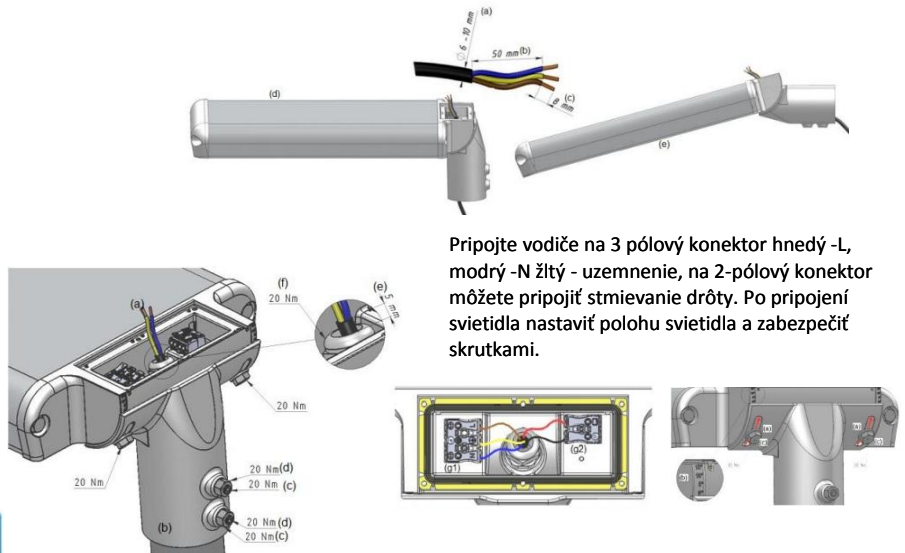

Pripojte vodiče na 3 pólový konektor hnedý -L, modrý -N žltý - uzemnenie, na 2-pólový konektor môžete pripojiť stmievacie drôty. Po pripojení svetidla nastaviť polohu svetidla a zabezpečiť skrutkami.





## POULIČNÉ LED SVIETIDLÁ

SÉRIA LUX - 72W

DLP1A6A50A

LM-79

LM-80

DLC

### APLIKÁCIE

Verejné osvetlenie ulíc, parkov, nádvorí.

### MONTÁŽ

Montáž na stĺp vrejného osvetlenia vo výške 7-10m

### TECHNICKÁ ŠPECIFIKÁCIA

Napájanie	AC 100-240V/277V, 50/60Hz
Príkion	72W
Vyžarovací uhol	135x55°
Svetelný tok	95-130LM/W
CRI	70-83 Ra
ČIP	CREE XTE
LED napájač	MEANWELL HLG
Materiál svietidla	Eloxovaný hliník 6063
Optika	PMMA
Svetelný tok	>80000 hod-L70(9K),@25°C
Pracovná teplota	mín 30°C ~ 50°C
Účinník	> 0,9
Krytie	IP66, IK08
Rozmery	658x275x65,5 mm
Váha	8,4kg

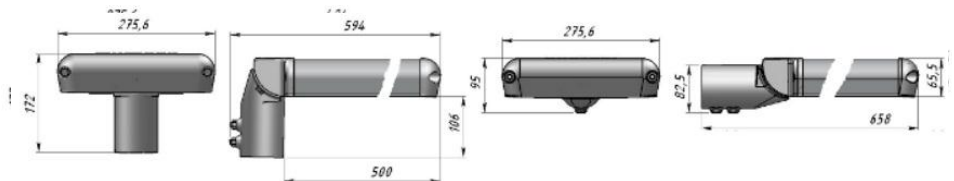
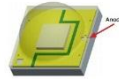

### CERTIFIKÁCIA



### VYŽAROVACIA CHARAKTERISTIKA

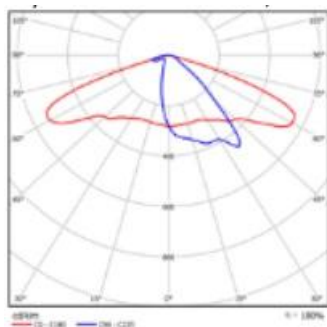

### MONTÁŽ LED SVIETIDLA

Príprava kabeľáže svietidla pre zapojenie

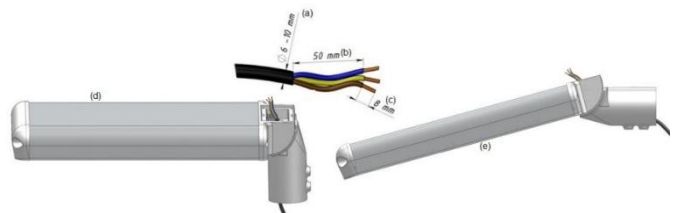

Pripojte vodiče na 3 pólový konektor hnedý -L, modrý -N žltý - uzemnenie, na 2-pólový konektor môžete pripojiť stmievanie drôty. Po pripojení svietidla nastaviť polohu svietidla a zabezpečiť skrutkami.

